

(No Model.)

H. COTTRELL.
EXPANDING MANDREL.

No. 249,143.

Patented Nov. 1, 1881.

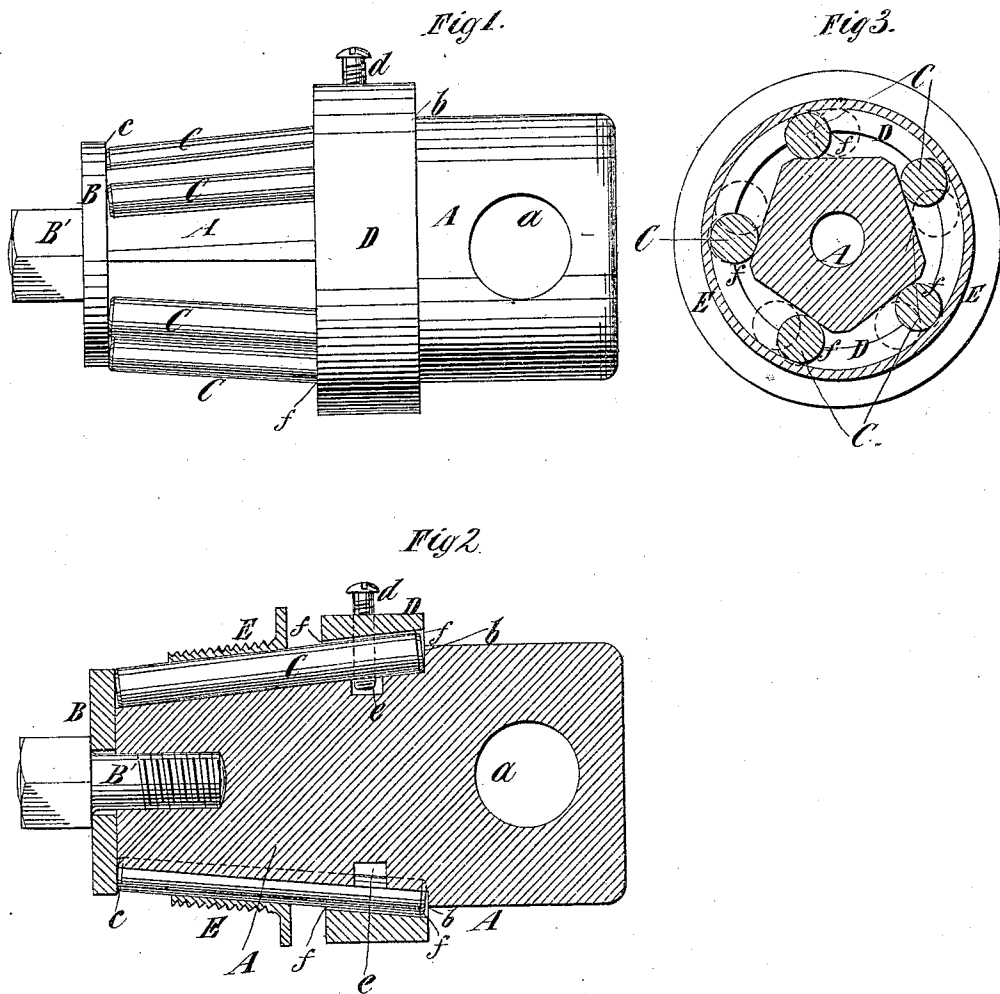

WITNESSES
Fred Haynes
George H. Potter

INVENTOR
Herbert Cottrell
by his Attorneys
Brown & Brown

UNITED STATES PATENT OFFICE.

HERBERT COTTRELL, OF NEWARK, NEW JERSEY, ASSIGNOR TO HIMSELF AND JOHN H. BARLOW AND HOWARD C. CONDIT, BOTH OF SAME PLACE.

EXPANDING MANDREL.

SPECIFICATION forming part of Letters Patent No. 249,143, dated November 1, 1881.

Application filed July 5, 1881. (No model.)

To all whom it may concern:

Be it known that I, HERBERT COTTRELL, of the city of Newark, in the county of Essex and State of New Jersey, have invented certain new and useful Improvements in Expanding Mandrels, of which the following is a specification.

My invention is applicable to mandrels which are to be rotated on centers in a lathe, to chucks which are to be fixed upon the headstocks of lathes and receive hollow articles to be turned, and to tools or wrenches which may be employed for screwing bung-bushings into barrels, and for other like uses. Such mandrels, chucks, and tools all resemble each other, in that they are adapted to be inserted into annular or hollow articles and then expanded to hold said articles fixed upon them, so that they will rotate with them, and hence they may all be termed "expanding mandrels."

The invention consists in the combination, in an expanding mandrel, of a circularly-arranged series of rollers, a ring or collar, whereby said rollers are held in proper relation to each other while permitting them to be moved outward, and a center or body which occupies a fixed longitudinal position relatively to said rollers and is adapted to be partially turned in said ring or collar, and which has cam-like projections upon its perimeter, which act upon said rollers to force them simultaneously outward, and thus expand the mandrel.

In the accompanying drawings, Figure 1 represents a side view of one form of my improved mandrel. Fig. 2 represents a central longitudinal section thereof and of a bushing fitting thereon, and Fig. 3 represents a transverse section of said mandrel and bushing.

Similar letters of reference designate corresponding parts in all the figures.

The several figures of the drawings illustrate my invention embodied in a tool or wrench for screwing bung-bushings into barrels.

A designates the body or center of the mandrel, which comprises a cylindrical head portion, in which is a hole, *a*, for the insertion of a bar, whereby it may be turned, and which also comprises a taper portion smaller than said head portion and of polygonal form in its transverse section, as clearly seen in Fig. 3. At each end

of the taper polygonal portion of the body or center A is a shoulder, the shoulder *b* at the larger end being formed in the piece itself, and the shoulder *c* at the smaller end being formed by a flange or washer, B, secured by a bolt, B'. In lieu of being formed by a separate piece, the shoulder *c* might be formed in one piece with the body or center.

C designates rollers, which are arranged in a circular series, and are equal in number to the sides of the polygonal center or body A, which in this example of my invention has five sides. The rollers C are of a length to fit loosely between the shoulders *b c*, as seen in Fig. 2, and their end movement relatively to the body or center is thereby prevented.

D designates a collar fitting loosely upon the center or body A, and secured against movement longitudinally thereof by a set-screw, *d*, entering a groove, *e*, in said center or body. In the inner surface of the collar D are a number of half-round bearings, *f*, in which the rollers C fit, and by which they are kept at the proper distance apart; but said rollers fit so loosely in said bearings that they may move outward to some extent.

E designates a bung-bush of common form, which is taper on the interior as well as the exterior, and into which the mandrel is inserted, with the collar D so placed relatively to the body or center A that the rollers C will each be in the center of one of the flat sides of the polygonal center or body, as indicated by the dotted lines in Fig. 3. If the collar D be now held stationary in the hand while the center or body is turned, the sides of the polygonal portion will act upon the rollers C and force them outward against the interior of the bushing, thereby locking the latter fast to the mandrel and causing it to turn therewith as the mandrel is turned. After the bushing has been screwed home a slight turn of the mandrel in the other direction will loosen it, and it can then be easily withdrawn.

If the center or body A had a screw-socket in its head, it might be screwed upon the head-spindle of a lathe and employed for chucking hollow articles to be turned.

The mandrel might be made of considerable

length and adapted to rotate upon lathe-centers, and its center or body might be straight, instead of taper, as here shown.

5 Instead of the center or body being of polygonal form, it might be of other cam-like form, which would enable it to act upon the rollers when turned.

10 I am aware that an expanding mandrel has been made in which a series of rollers are forced outward by means of a conical or taper center which is screw-threaded above the rollers, so that as it is turned it is forced inward or advanced between the rollers to cause its taper to force them outward. This I do not
15 claim as of my invention.

What I claim as my invention, and desire to secure by Letters Patent, is—

1. In an expanding mandrel, the combination of a circularly-arranged series of rollers,

a ring or collar, whereby said rollers are held 20 in proper relation to each other while permitting them to move outward, and a center or body which occupies a fixed longitudinal position relative to said rollers and is adapted to be partially turned in said ring or collar, 25 and which has cam-like projections upon its perimeter, which act upon said rollers to force them outward, substantially as specified.

2. The combination of the center or body A, comprising a polygonal portion and shoulders 30 *b c*, the rollers C, fitting between said shoulders, and the ring D, comprising bearings *f*, for said rollers, substantially as specified.

HERBERT COTTRELL.

Witnesses:

FREDK. HAYNES,
EDWARD GLATZMAYER.